

## RESEARCH NOTES

### A TRAP TO CAPTURE BURROWING ARACHNIDS

In studies of population biology, it is often necessary to determine size and reproductive status of individuals and to mark them for later recognition. This process should assure minimal disturbance of study subjects and of their natural

surroundings. Current techniques for capturing burrowing arachnids, however, often involve disturbance, such as excavation. This destroys burrows and risks injuring animals.

Several alternative techniques for capturing

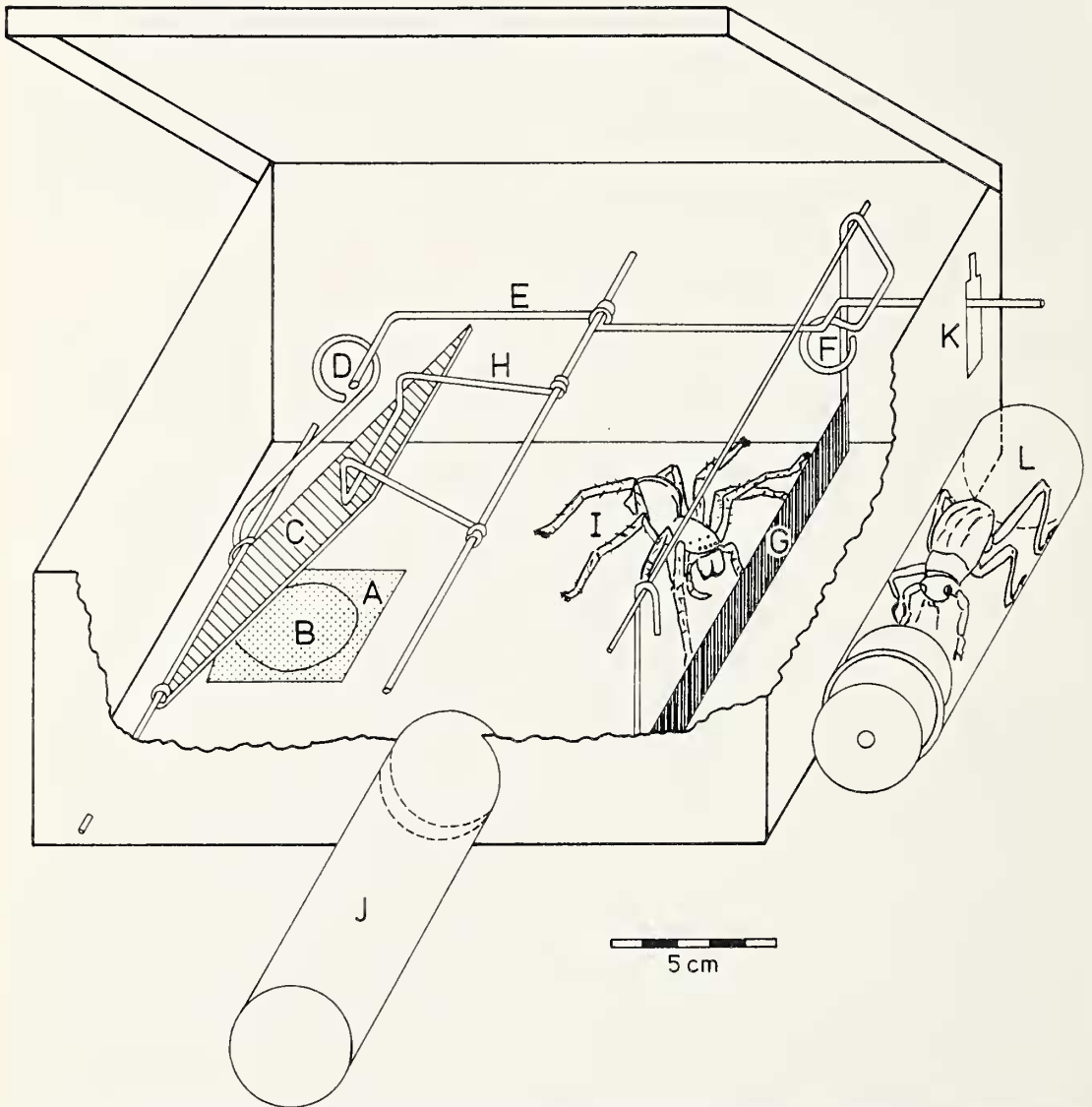

Figure 1.—Components of the spider trap in the set position: A, hole in bottom of trap; B, entrance of spider burrow; C, door of trap; D, door-lever; E, balancing shaft; F, trigger-lever; G, trigger; H, locking hook; I, spider; J, open vial to provide spider with shelter; K, slit to lock shaft; L, vial with live bait.

large, burrowing, wandering spiders were tested in a population study of *Leucorchestris arenicola* Lawrence, a heteropodid (Henschel 1990). When disturbance caused by excavation proved unacceptable, pitfall traps were employed. Trapping success was, however, low because spiders usually detected and circumvented the edges of pits. Furthermore, individual spiders could not be targeted.

Therefore, I designed a container trap, described here, which is cheap to make and easy to operate. It capitalizes on a spider's tendency to probe when surrounded by a container. This probing mechanically triggers closure of an artificial trapdoor that prevents the spider from retreating into its burrow, thus capturing it inside the container.

The sensitive trigger mechanism enables one to capture burrowing arachnids having a mass of 0.5 g or more. I have used it to capture more than 100 spiders of two species and one scorpion on surface slopes of 0–30° and in winds of 0–5 m/s.

The body of the trap (Fig. 1) is made of a rectangular, flat-bottomed container (base  $\pm 12 \times 20$  cm, height  $\pm 5$  cm) with a transparent, airtight lid. A commercially available 2-liter plastic container for food, such as an empty ice-cream tub, is suitable. All other components besides sample vials are made of 1.5-mm-gauge stiff wire and tape.

The description of components refers to labels on Figure 1. A hole of  $4 \times 4$  cm (A) is cut into the bottom near one end of the container. This hole is larger than the natural trapdoor of a spider burrow entrance (B) and is covered with a stiff wire-rimmed  $5 \times 5$  cm door (C), hinging on a straight piece of wire attached to the body of the trap. The door is held open by leaning a door-lever (D), fixed to one side of the door, against a balancing shaft (E) suspended across to the other end of the trap. The heavier proximal end of this balancing shaft rests on a trigger-lever (F) connected to a wide, low-hanging trigger (G).

The trigger-lever and door-lever are circular so that trigger sensitivity is less dependent on the extent of overlap of contact points. If the trigger is pushed only lightly ( $< 0.1$  g force =  $9.806 \times 10^{-4}$  Newtons), the heavier end of the balancing shaft drops off the trigger-lever, moving the distal end clear of the door-lever and the door closes by gravity. Simultaneously, a broad hook (H) drops onto the door to lock it (Fig. 2).

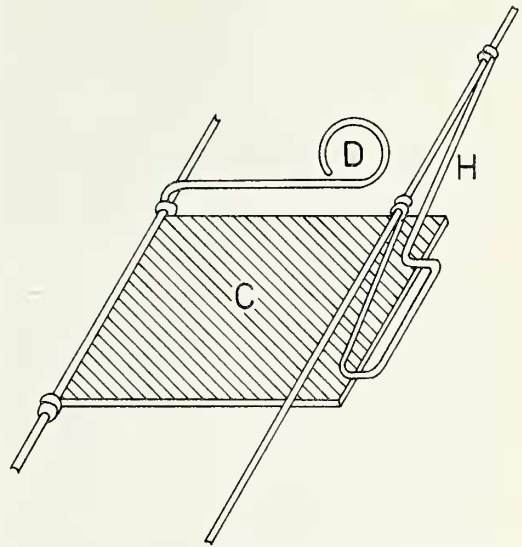

Figure 2.—Closed door of trap locked into place by a wire hook.

The trigger is positioned away from the door so that the spider (I) does not obstruct the slamming door. Although a spider is capable of lifting the door to enter its burrow, it cannot at the same time lift the locking hook and the door. Deprived of other shelter, it readily enters a darkened vial (J) extending through the side of the trap. This tube is later removed to manipulate the spider.

The trap has to be opened to set it. As the trigger is very sensitive to wind until the lid is closed, the balancing shaft can be locked into position by forcing it into the narrowest top part of a slit (K) in the wall of the trap. When the trap is set and the lid closed, the balancing shaft is loosened by lowering it into a wider section of this slit until the balancing shaft is held only by the trigger-lever.

Several factors increase trapping success. Movements of live bait placed in a vial (L) outside the trap attracts the spider towards the trigger. To overcome the spider's initial reluctance to step onto the artificial surroundings, the floor of the trap is covered with sand. On slopes, the trigger should be downhill of the door. In windy conditions, shifting of the trap is prevented by pegging it through its base behind the trigger. Weight of the trigger and shapes of door- and trigger-levers determine the minimum size of arachnids that can be captured.

I thank the Foundation for Research Development for funds, the Ministry of Wildlife Con-

ervation and Tourism of Namibia for facilities, T. Harms for help and M. Seely for comments.

Museum Monograph No. 7. Transvaal Museum, Pretoria, pp. 115-127.

#### REFERENCES CITED

Henschel, J. R. 1990. The biology of *Leucorchestris arenicola* (Araneae: Heteropodidae), a burrowing spider of the Namib Desert. *In* Current Research on Namib Ecology—25 Years of the Desert Ecological Research Unit. (M. K. Seely, ed.). Transvaal

**Johannes R. Henschel:** Desert Ecological Research Unit of Namibia, P.O. Box 1592, Swakopmund, Namibia

*Manuscript received May 1990, revised August 1990.*